

◀ BIFACIAL DUAL GLASS ▶

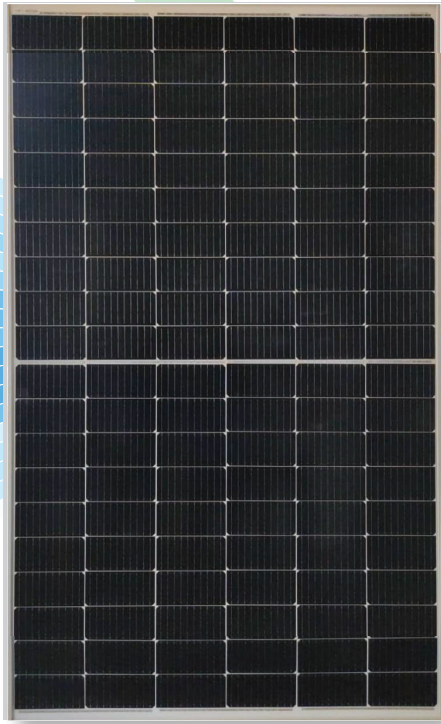

DESERV® EXTREME 120 430 WP - 455 WP



*Module image for representation purpose only



SAFE

- IP68 Junction box
- 10 YEARS 10 years of product warranty
- 25 YEARS 25 Years of power output warranty
- 1500 Vdc



RELIABLE

- Extreme weather resilience
- Windspeed - 2400 Pa, Snowload - 5400 Pa
- Highly reliable anti-reflective coated glass



HIGH PERFORMANCE

- PID resistant
- Superlative performance in low light
- High power density
- Positive power tolerance

World-class products, Made in India

- Smart:** High module efficiency with 120X half-cut Mono crystalline Bi-facial PERC Solar Cells
- Modern:** Processed on state-of-the-art technology production lines
- Dependable:** Use of highest quality raw materials coupled with rigorous in-house testing
- Versatile:** Suitable for Utility, Rooftop, and other general applications

Certifications:

- IEC Compliant
- IMS Certified Company - ISO 9001: 2015
- OHSAS 45001: 2018
- EMS - ISO 14001: 2015
- Independently audited by SOLARBUYER



RenewSys is the first integrated manufacturer of Solar PV Modules and its key components - Encapsulants (EVA and POE), Backsheets and Solar PV Cells. We have a global presence with offices in India, Mauritius, Nigeria, South Africa, Singapore, UAE, representatives in Europe, USA, Mexico, and an evolving distributor network.

Registered Office: Unit No. 607, 6th Floor, Trade Center, Bandra-Kurla Complex, Bandra East, Mumbai - 400 051, Maharashtra, India.

Factory: Plot No. E-141, Additional Patalganga MIDC Industrial Area, Village - Karade Khurd, Taluka Panvel, District Raigad - 410 206, Maharashtra, India.

Factory: Plot No.6, Survey # 114/P, Srinagar Village, Maheshwaram Mandal, Dist - Rangareddy, Hyderabad - 501 359, Telangana, India.

Performance under standard test conditions (1000w/m², AM 1.5, 25 °C)

DESERV Extreme 120 Bi-Facial Gain @Different Albedo (%)												
	Pm (Wp)	Vmp (V)	Imp (A)	Voc (V)	Isc (A)	Efficiency (%)	Pm (Wp)	Vmp (V)	Imp (A)	Voc (V)	Isc (A)	Efficiency (%)
Front @STC	430	35.00	12.31	41.16	12.94	19.83	435	35.21	12.37	41.20	13.08	20.06
5%	451.5	35.00	12.90	41.16	13.53	20.82	456.7	35.21	12.97	41.20	13.68	21.06
10%	473.0	35.00	13.51	41.16	14.14	21.81	478.5	35.21	13.59	41.20	14.30	22.07
20%	516.0	35.00	14.74	41.16	15.37	23.79	522.0	35.21	14.83	41.20	15.54	24.07
Front @STC	440	35.39	12.45	41.37	13.16	20.29	445	35.52	12.55	41.60	13.23	20.52
5%	462.0	35.39	13.05	41.37	13.76	21.30	467.2	35.52	13.15	41.60	13.83	21.55
10%	484.0	35.39	13.68	41.37	14.39	22.32	489.5	35.52	13.78	41.60	14.46	22.57
20%	528.0	35.39	14.92	41.37	15.63	24.35	534.0	35.52	15.03	41.60	15.71	24.62
Front @STC	450	35.64	12.65	41.85	13.31	20.75	455	35.78	12.74	42.10	13.37	20.98
5%	472.5	35.64	13.26	41.85	13.92	21.79	477.7	35.78	13.35	42.10	13.98	22.03
10%	495.0	35.64	13.89	41.85	14.55	22.83	500.5	35.78	13.99	42.10	14.62	23.08
20%	540.0	35.64	15.15	41.85	15.81	24.90	546.0	35.78	15.26	42.10	15.89	25.18

NOCT (Wp) at 45 ± 2 °C @800 W/m ²	430	435	440	445	450	455
Pmax (W)	320.02	323.74	327.46	331.18	334.90	338.63
Max. power voltage (Vmp), V	32.01	32.20	32.37	32.49	32.60	32.72
Max. power current (Imp), A	10.02	10.07	10.13	10.21	10.30	10.37
Open circuit voltage (Voc), V	38.27	38.31	38.47	38.68	38.91	39.15
Short circuit current (Isc), A	10.57	10.69	10.75	10.81	10.87	10.92

Bi-faciality factor: 70 ± 5%

Mechanical Characteristics

Cable	No. 12 AWG, 4mm ² , (300mm Standard)
PV Connectors	MC4 Compatible
Frame	Anodized Aluminum Alloy
Junction box	IP68 Split junction box with 3 bypass diodes
Glass (front)	2.0mm AR coated low iron heat strengthened
Glass (back)	2.0 mm Low iron heat strengthened

Operating Conditions	
Temperature, °C	-40 to +85
Max. system voltage, Vdc	1500
Hail impact velocity, m/sec	23
Max. surface load capacity, Pa	5400
Max. wind speed capacity, Pa	2400
Series fuse rating, A	30

Physical Parameters	
No. of cells	120
Module dimension (mm)	1914 X 1133 (± 2)
Module thickness (mm)	35
Approximate weight (kg)	26.5

Cell Temperature Coefficient	Bi-Facial
Open circuit voltage	-0.2588 % / °C
Short circuit current	+0.0733 % / °C
Peak power	-0.3287 % / °C

Test uncertainty for Pmax ± 3%

Bi-facial gain subject to mounting structure specifications and albedo % of ground

- Please refer to the installation manual for detailed information.

Frame Cross Section

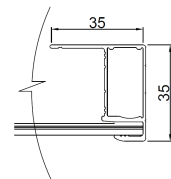

Mounting Hole

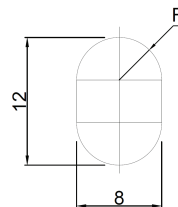

Module Dimension Diagram (mm)

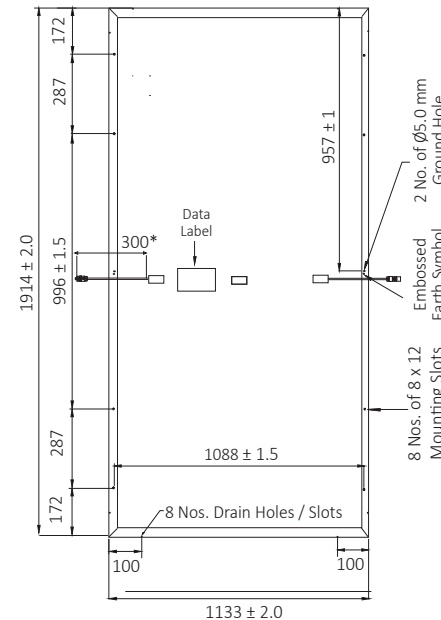

IV Curves

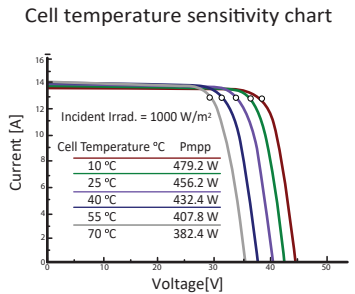

Incident irradiance sensitivity chart

